



2222 Cuming Street, Omaha, Nebraska 68102-4392
(402) -341-0800 ☒ Fax (402)-342-0949 ☒ TDD: 4(402)-341-0807

Operated by Transit Authority of the City of Omaha

Project: Ne-90-X104

Spec: 14-16

Exterior Repairs – Sidewalk Repair

Issued: June 19, 2017

The Transit Authority of the City of Omaha d/b/a/ Metro, is requesting informal quotes for the repair of sidewalks at our Administrative building located at 2222 Cuming St, Omaha NE.

Over time, sidewalks abutting a retaining wall on the west side of Metro's Administrative Facility have become uneven and have pulled away from the retaining wall. The sidewalks have also sunk, due to subgrade being washed out from under the slab.

This quote is for a one-time repair, leveling, evening and sealing of the side walk in order to stop subgrade wash and properly drain water from the retaining wall to the street. Affected work area is approximately 1,772 square feet.

Federal Davis-Bacon wage rates will prevail for this contract (Attachment 2.) Davis-Bacon wage checks will be completed weekly during the duration of this project. Appendix E Must be signed.

Payment will be within 30 days of submission of; completed, correct invoice and completed, correct and verified payrolls. This contract will be paid for with federal, state and local funds.

A confirmation of receipt and agreement with the Federal Clauses (Attachment 1) must be signed as a portion of this solicitation (Appendix D.)

Designated Metro Staff will be responsible for reviewing work for completion prior to payment.

Quoted price shall not include federal, state or local taxes. Metro is tax exempt and shall furnish a tax exempt certificate and number, upon request.

PRE-QUOTE CONFERENCE AND WALK-THRU

- A. A Pre-Quote Conference and Site Walk-Thru will be held **Thursday July 6th, 2017 at 9:00 a.m.**, at the project site, 2222 Cuming Street, Omaha, NE, 68102. Attendees will meet in the Board Room. This meeting will include a review of the scope of work, tour of the prospective job site and interested firms will have an opportunity to ask questions.
- B. **While not mandatory, it is strongly suggested interested companies attend.**

REQUESTS FOR CLARIFICATION AND/OR SUBSTITUTIONS / APPROVED EQUAL

- A. If any interested firm is in need of clarification of any part of the Contract Documents and/or would like to request a substitution / approved equal, they may make the request by using the Request for Clarification form and/or the Request for Substitution / Approved Equal form included in this Project Manual.
- B. Request for Clarification and/or Substitution/Approved Equal forms shall be submitted on the appropriate form via email to procurement@ometro.com on/before **10:00 AM, Monday, July 10th, 2017**.
- C. Clarifications and Substitutions will be reviewed and a response provided by Addendum will be posted on Metro's website www.ometro.com on/before **4:00 p.m., Friday, July 14th, 2017**. Verbal instructions or interpretations shall have no validity regardless of source.

REQUIREMENTS BEFORE SUBMITTING QUOTES

- A. Thoroughly examine the site and any building located thereon in relation to conditions which might directly or indirectly affect the Work. The lump-sum quote shall reflect all such affecting conditions. Interested firms shall be responsible for verifying conditions and dimensions that may affect the Work.
- B. Verify all language and requirements of the Quote Document. Ensure the following are completed, dated and signed:
 - a. APPENDIX A: Price Schedule
 - b. APPENDIX B: Request for Clarification/Substitution
 - c. APPENDIX C: Acknowledgement of Addendum
 - d. APPENDIX D: Receipt of Federal Clauses Acknowledgement
 - e. APPENDIX E: Davis-Bacon Wage Acknowledgement

HOW TO SUBMIT YOUR QUOTE

Take the steps below to submit your quote:

1. Locate:
 - a. Pricing Schedule (Appendix A)
 - b. Receipt of Acknowledgement of Addendum (Appendix C)
 - c. Receipt of Federal Clauses Acknowledgement (Appendix D)
 - d. Davis Bacon Wage Acknowledgement (Appendix E)
2. Double check:
 - a. Dates
 - b. Monetary values
 - c. Signatures
3. Metro prefers your quote to be submitted electronically to procurement@ometro.com. If you are not able to submit via email you can:
 - a. Mail it to the Grant Administrator at 2222 Cuming Street, Omaha, NE 68102
 - b. Fax it to (402) 342-0949
 - c. Hand deliver it to 2222 Cuming Street, Omaha, NE, 68102
4. **Due Date (regardless of submission method): on or before 4:00 pm, Central Time, Tuesday July 18, 2017.**
5. Confirm Metro’s receipt by contacting the Grant Administrator at procurement@ometro.com or (402) 341-7560, Ext: 2601.

SCHEDULE OF DATES

Activity	On or Before		
	Time (CST)	Day	Date
Pre Quote walk through	9:00 am	Thursday	July 6 th , 2017
Request for Clarification Due	10:00am	Monday	July 10, 2017
Post final answers to requests for substitutes and clarifications.	4:00 pm	Wednesday	July 14 th , 2017
Quote Due Date - procurement@ometro.com preferred method to receive quotes	10:00 am	Tuesday	July 18, 2017
Contract Award – Issue Notice to Proceed		Thursday	July 20, 2017
Work and completion to be coordinated with Metro Project Director			

All dates are estimated and subject to revision at the sole discretion of Metro. Attendance at the Pre-Quote walk through is strongly recommended. Interested bidders should meet at Metro’s administrative facility at **2222 Cuming Street in Omaha, Nebraska on Thursday, July 6th, 2017 at 9:00 a.m.** The walk through will include a tour of the area work is to be done.

Quote Selection

Quotes, unlike sealed bids, are not opened in public. Metro will review the quotes to determine if any of them are ineligible for future consideration. Metro will award a contract to the firm who provides the low, responsive, responsible quote.

Metro reserved the right in its discretion to: amend the Request for Quotes at any time prior to the due date by Addendum; reject all quotes; to waive minor irregularities contained in any quote; rely upon information obtained through its own investigation of the firm or its quote or that of any department, agency or any other appropriate governmental entity; and withdraw the Request for Quotes at any time, including after the due date, without awarding a contract.

Metro will ensure that the lowest bidder is fully responsible and capable of carrying out the scope of work prior to awarding a contract. Metro will only award a contract to a bidder that is determined to be responsible and possesses the ability, willingness, and integrity to perform successfully under the terms and conditions of the contract. Federal law codified at 49 U.S.C. 5325(c) authorizes Metro to award a contract to other than the lowest bidder if the award furthers and objective consistent with the purposes of 49 U.S.C. Chapter 53 including but not limited to lower long-term costs and improved long-term operating efficiency.

PROTESTS

1. Protests made in connection with this solicitation shall be limited to those allowable by, and made in compliance with, the procedures established by the Authority, copies of which may be obtained from the Executive Director of the Authority upon written request. All protests shall be concise, direct and sufficient to permit the Authority to determine the full and complete basis therefore, fully supported by all current, relevant objective information, documentation or support considered necessary by the protestor that is completely accurate in all material respects. Procedures for appeals from any such decision are set forth in the Authority's protest procedures.
2. Protest of a denial or approval of any request for clarification or approved equal shall be made in writing received by the Grant Administrator by no later than ten (10) business days before the due date. The Authority shall decide the protest by no later than five (5) business days prior to the due date.
3. Protest of the award of a contract must be made in writing received by the Executive Director of the Authority not later than ten (10) business days after the earlier of the award of the Contract or the announced intention of the award of the Contract.
4. The filing or approval of any protest or appeal may result in the extension of the due date, the issuance of an Addendum, the withdrawal of the solicitation or the reconsideration of any award of a contract, in the sole discretion of the Authority.
5. In the event of an appeal from the award of a contract, the award shall not be considered final or binding upon the Authority unless the award is thereafter confirmed in writing by the Executive Director.

6. For information purposes only, the Federal Transit Administration (FTA) will not accept any protest or appeal from any decision of the Authority unless the Authority fails to have any written protest procedures, the Authority fails to follow such procedures or the Authority fails to review a timely protest. An Applicant must exhaust all administrative remedies with the Authority before pursuing a protest with FTA. An appeal to FTA must be received by the appropriate FTA regional or Headquarters Office within five (5) business days of the date the Applicant knew or should have known of the violation.

SCOPE OF WORK

The contractor will provide all necessary and needed labor, tools, supplies, materials, equipment, services and supervision to complete the following:

- 1) Remove existing sealant from joints between sidewalk, curb and retaining wall. Joint cleaner will be non-corrosive and non-staining, compatible with joint forming materials; use will be as directed by manufacturer.
- 2) Level sidewalk to proper slope, not less than 1/8" per foot and a maximum of 1/2" per foot slope from retaining wall to curb, to ensure proper drainage. Each slab leveled should be leveled to adjoining slab, with no trip/fall hazard presented by difference in heights between slabs and be uniformly level across the area worked.
 - i. Preferred method would be to use a slab jacking technique, with use of solidifying cement based grout.
 - ii. It is requested Polyurethane Foam not be used for this project.
- 3) Fill and seal any penetrations in concrete work necessary to perform the above functions.
- 4) Prepare joints for sealant. Prepare and size joints, per manufacturer's instructions. Clean substrates of dirt, laitance, dust or mortar, using solvent, abrasion or sandblasting, as recommended by manufacturer. Remove loose material and foreign matter might impair adhesion of sealant.
- 5) Install Backer Rod, as required by manufacturer.
 - i. Backing material will be closed foam, set at proper depth for sealant used. Backer bar should be 30% to 50% larger than joint width. Follow manufactures instructions on surface preparation and backer bar placement.
- 6) Seal level sidewalk joints and ends to retaining wall, curb and adjoining slabs, using backing material, prior to sealant.
 - i. Sealant will be one-part, non-leveling pavement sealant that is permanently flexible, with low to ultra-low modulus and high-elongation silicone rubber. The sealant must have good weatherability. Sealant must withstand extension of at least 100 percent and compression of 50 percent of the original joint width. The sealant cures upon exposure to moisture in the air and requires tooling for finishing. Sealant is to be polyurethane, no asphalt will be approved.
 1. Sealant is to be applied per manufacturer recommendations for joint preparation and environmental conditions for application of sealant.
 - ii. Sealant should be between 3/4" to 1" deep to backer rod and set 1/8" below surface, when finished. (See Diagram A)

- 7) Using the same technique as above, seal any cracks in concrete slabs which may allow moisture into subgrade, following above instructions.
- 8) Clean, remove and dispose of any and all debris created by the accomplishment of the above.

End result should be properly aligned sidewalk, from retaining wall to curb and from slab to slab, with no trip/fall hazards and sealed against water penetration.

Contractor must adhere to all laws, rules and regulations for public sidewalk surface finishing, including, but not limited to The American with Disabilities Act.

By bidding on this job, contractor agrees to dispose of any and all waste created by this project in accordance with all federal, state and local laws regarding disposal.

By bidding this job, contractor agrees to follow Metro safety rules. Area being worked in will be designated by barrier or barricades and signs, as needed.

Contractor also agrees its employees will adhere to Metro personal safety rules such as; hearing protection, eye protection and high visibility clothing use, while performing work on Metro property.

Please Note: Work will be done when environmental conditions, such as ambient air temperature, ground temperature and other conditions such as predicted precipitation, allow. Actual work will be coordinated with Metro Project Director.

Diagram A

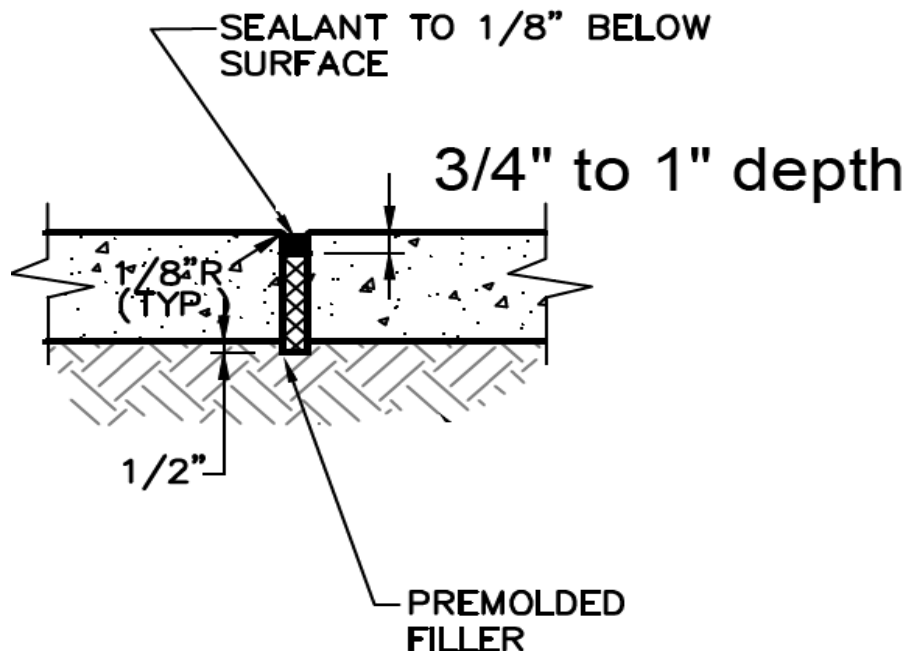

GENERAL CONDITIONS

1.0 Definitions. Whenever used in this RFQ, the following capitalized and other terms shall have the meaning ascribed to them set out below, and as may otherwise be defined in this RFQ.

ADDENDUM	A written amendment or modification to the RFQ, issued by Metro in conformity with the RFQ.
APPLICANT	Person who submits a Technical Proposal Offer. The term "Bidder", "Offeror", or "Respondent" is occasionally used in the Laws or Contract Documents to mean the Applicant or the Contractor. Such term shall therefore be construed to apply to Applicant whenever the context shall require.
AUTHORITY	Transit Authority of The City of Omaha d.b.a. Metro. The term "Metro" is used in the Laws or Contract Documents to mean Metro.
CONTRACT	The agreement between the Contractor and Metro to perform the Work for the Project. The Contract shall consist only of the Contract Documents, including: their respective covenants, terms, conditions and other provisions; and any exhibits, schedules, drawings, specifications or other instruments or documents referenced in, by, or otherwise incorporated into, any Contract Documents. To the extent there exists any inconsistency among the Contract Documents that which is deemed by Metro to be most advantageous shall apply. The performance of the Contractor, including that of its Subcontractors, shall conform to, and shall be consistent with, the Contract. The Contract shall continue until the completion of the performance of the Work, unless earlier terminated.
CONTRACT DOCUMENTS	The Contract Documents shall mean and include: the RFQ; the Technical Proposal Offer, including any permitted or negotiated modifications/ amendments thereto; any executed Acknowledgement of Addenda; any Request for Clarification and Approved Equal; any executed Certification required by the RFQ (see, Attachment "D"); the Contract award; all bonds and policies or evidence of insurance; any separate written agreements between Metro and the Contractor related to the Project or the Work, including, if required, a duly executed and completed contract; any other material or document designated by Metro as a Contract Document.

CONTRACTOR	The Applicant receiving the award of a Contract. Unless otherwise required by this Contract, references to the Contractor shall include Contractor and Subcontractors, including its and their employees, agents, successors and assigns. The term "Bidder" or "Offeror" is occasionally used in the Laws or Contract Documents to mean the Applicant or the Contractor. Such term shall therefore be construed to apply to Contractor whenever the context shall require. Similarly, the term "installer", "third party contractor", "lower tier participant" shall therefore be construed to apply to Contractor whenever the context shall require.
DAYS	Days shall mean business days unless otherwise expressly provided.
D.O.T.	Department of Transportation.
F.T.A.	Federal Transit Administration.
INCLUDING	The term "including" shall mean "including without limitation", whether or not expressly so provided.
LAW	"Law" or "Laws" means and refers to all existing and future applicable federal, State and local laws, requirements, provisions, conditions, policies, directives, procedures, orders, rules or regulations (including those of any federal, State or local agency or department having jurisdiction over any such matters) that may pertain to or otherwise relate to the Services or to the resultant Contract, as any such Law may be from time to time amended, supplemented or supplanted. Laws include but are not limited to those federal requirements included, identified or referenced in Attachment "C" of this RFQ, all applicable FTA regulations, and all Environmental Regulations. An "Environmental Regulation" is any federal, state, or local statute, law, ordinance, rule, regulation, or policy governing the use, storage, treatment, transportation, manufacture, refinement, handling, production, discharge, emission, or disposal of any Hazardous Substance or otherwise relating to the protection of the environment or to otherwise implement or comply with any Environmental Regulation; and "Hazardous Substance" shall have the meaning given to such phrase in the Comprehensive Environmental Response, Compensation and Liability Act of 1980, as amended (42 U.S.C. § 9601, et seq.) and any other Environmental Regulation, any flammable explosives, radioactive materials, hazardous materials, hazardous wastes, hazardous or toxic substances, or any related

materials or any materials that are regulated by any other Environmental Regulation.

MASTER AGREEMENT	Agreement between the F.T.A. and Metro.
PARTY(IES)	Metro or the Contractor individually (or collectively).
PERSON	“Person” shall mean any individual or entity, including any corporation, partnership, sole proprietor or LLC.
PROJECT NO.	Metro Project No. <u>NE-90-X104 Spec: 14-16 Exterior Repairs – Sidewalk Repair</u> . All written correspondence from a Party in connection with the Contract Documents, the Contract or the Work shall reference the Specification No. and the Project No.
PROJECT COMPLETION DATE	The date designated in the Contract Documents for completion of the Work, as extended in conformity with the Contract Documents.
RFQ	This REQUEST FOR PROPOSALS for Project No. <u>NE-90-X104: Specification No. 14-16 Exterior Repairs – Sidewalk Repair</u> , issued <u>June 19, 2017</u> consisting of those items identified, together with any Appendices and Addenda.
RECIPIENT	Metro.
SPECIFICATION NO.	Metro Specification No. <u>14-16 Exterior Repairs – Sidewalk Repair</u> . All correspondence from a Party in connection with the Contract Documents, the Contract or the Work shall reference the Specification No. and the Project No.
SPECIFICATIONS	The Project/Scope of Work included in this RFQ.
SUBCONTRACTOR	Any Person with whom the Contractor subcontracts any Work, including any Person from whom Contractor may purchase any equipment, materials or services. All agreements between Contractor and Subcontractors shall be in writing, conform to the Laws and shall be assignable, without penalty or modification, to Metro upon request in the event of termination of the Contract.
SUB-RECIPIENT	A Person to whom the recipient distributes federal funds.
TECHNICAL PROPOSAL	A timely written response to this RFQ that complies in all material respects to this RFQ and includes a proposed price for the Work. The Technical Proposal Offer shall include any

forms, Certifications or other materials required by the RFQ. The term "Bid" or "Technical Proposal" or "Offer" is occasionally used in the Laws or Contract Documents to mean the Technical Proposal and shall be so construed whenever the context shall require.

WORK

The work and performance required by the Contract, including all tangible and intangible property (including, unless otherwise expressly provided in the Scope of Work, all designs, drawings, photographs, data, specifications, computer records and software, lists, manuals, reports, research, source codes, all related information, intellectual/proprietary property rights therein and thereto), all licenses, purchases, construction, installation, labor, materials, equipment and services contemplated, made, prepared, developed, provided or to be made, prepared, developed, provided by the Contractor, including its Subcontractors. Unless otherwise provided in the Scope of Work, all Work, including partially completed Work, shall be the property of Metro, subject to the rights of the United States therein and thereto.

1.1 Responses to RFQ.

1.1.1 Responsive Quote.

- (a) The Authority will evaluate only those Quotes which are fully responsive to this RFQ and which are received by the Authority before Four (4) o'clock p.m., Central Time, Wednesday, July 18, 2017 or as extended by Addendum. Each Applicant shall submit 1 copy of a quote, addressed as follows:

14-16: Sidewalks
Grant Administrator
Transit Authority of the City of Omaha
2222 Cuming Street
Omaha, Nebraska 68102-4392
Or
procurement @ometro.com

- Quotes become the property of the Authority.
- (b) The Authority reserves the right in its discretion: to amend the RFQ at any time prior to the Proposal deadline by Addendum; to reject all Quotes; to waive minor irregularities contained in any quote; to rely upon any information obtained through its own investigation of the Applicant or its Quote or that of any department, agency or any other appropriate governmental entity; and to withdraw the RFQ at any time, including after the Proposal deadline, without the award of a Contract.
- (c) An Addendum to this RFQ shall be forwarded only to those Persons who have requested a copy of this RFQ in writing and who have provided an address, telefax or similar means of communication for such purposes to the Authority pursuant to this RFQ. Any Person who may have received a copy of this RFQ from the Authority or other sources without a written request to the Authority for the same must comply with this requirement. The Authority shall not be responsible should any Person failure to receive such Addendum or notice.
- (d) Quote may be withdrawn or modified by Applicant upon written request referencing the appropriate Project and Specification numbers addressed to the Grant Administrator prior to the Quote deadline. Whenever sealed Quote have been required, modifications shall also be sealed and shall be submitted to the Grant Administer, clearly marked "MODIFICATION TO SEALED QUOTE". Modifications will be accepted and considered only if received prior to the Quote deadline. All modifications shall clearly identify how and to what extent the Quote is being modified. Where appropriate, the required number of copies of substitute forms, documentation and other materials shall be included with the modification. Sealed Quote that are withdrawn shall be returned unopened by the Authority.
- (e) The Authority may request additional or clarifying information from an Applicant at any time. If only one Quote for the Work is received, a detailed cost proposal may be requested of the single Applicant. A cost/price analysis and evaluation and/or audit may be performed of the cost proposal

to determine fair and reasonable price. All responses from Applicant shall be in writing.

- (f) Sales taxes shall not be included in the price for any Proposal.
- (g) No Quote shall be considered compliant or responsive unless it materially complies with the RFQ in its entirety, completely and accurately responds to all parts of the RFQ and includes all information requested. Without limitation to the generality of the preceding sentence or any other provision of this RFQ, a Quote may be found not to be compliant or responsive if Applicant:
 - Misrepresents any material fact.
 - Attempts to evade any material provision or requirement of this RFQ.
 - Fails to timely submit a duly authorized and executed Quote.
 - Submits a conditional Quote, or a Quote that takes exception to the Specifications, the RFQ or any other Contract Document.
 - Fails to adequately demonstrate its ability to perform or timely perform the Project and the Work in compliance with the Contract.
 - Fails to fully execute or complete any forms, schedules or exhibits required by this RFQ to be executed or completed.
 - Otherwise fails to comply with any material provision or condition of this RFQ.

1.1.3 Requests/Specified Parts and “Approved Equals”.

- (a) This RFQ shall be the Authority’s official Request for Competitive Quote. No change can be made to this RFQ except in writing in the form of an Addendum signed by the Grant Administrator, in which event notice shall be provided to those Persons identified, and as set forth, in this RFQ. Other than a request for the RFQ, no inquiry concerning the RFQ shall be made except for clarification. All such requests must be made in writing on the form required and reference the Project and Specification numbers. Requests for clarification shall include an explanation detailing why clarification is necessary. All requests must be received by the Authority by the deadline specified in this RFQ or as extended by Addendum.
- (b) All requests to the Authority made under this Section 1.1.3 should be addressed as follows:

14-16: Sidewalks
Grant Administrator
Transit Authority of the City of Omaha
2222 Cuming Street
Omaha, Nebraska 68102-4392
Or
procurement@ometro.com

- (d) The Authority shall respond to all requests in writing in the form of an Addendum prior to the Proposal deadline. Copies of the response in the form of an Addendum shall be sent to all Persons complying with the RFQ. The Authority shall not be responsible should any such Person failure to receive such Addendum.
- (e) The Authority shall not be obligated to extend the Proposal deadline in the event of an approved request for clarification, substitutes or proposed equal, but may do so in its absolute discretion.
- (f) The Authority may reject any request for a substitute or qualified equal made by any Contractor following the award of the Contract, in its absolute discretion.

1.1.4 Protests.

- (a) Protests made in connection with this RFQ shall be made in writing received by the Grant Administrator by no later than the Quote deadline. Protests shall be limited to those allowable by, and made in compliance with, the procedures established by the Authority, copies of which may be obtained from the Executive Director of the Authority upon written request. All protests shall be concise, direct and sufficient to permit the Authority to determine the full and complete basis therefor, fully supported by all current, relevant objective information, documentation or support considered necessary by the Applicant that is completely accurate in all material respects.
- (b) Appeals from the award of a Contract must be made in writing received by the Executive Director of the Authority not later than ten (10) days after the earlier of the award of the Contract or the announced intention of the award of the Contract. Appeals shall be limited to those allowable by, and made in compliance with, the procedures established by the Authority, copies of which may be obtained from the Executive Director of the Authority. All appeals shall be concise, direct and sufficient to permit the Authority to determine the full and complete basis therefor, fully supported by all current, relevant objective information, documentation or support considered necessary by the Applicant that is completely accurate in all material respects. Procedures for appeals from any such decision are set forth in the Authority's protest procedures.
- (c) The filing or approval of any protest or appeal may result in the extension of the Quote deadline, the issuance of an Addendum, the withdrawal of the RFQ or the reconsideration of any award of a Contract, in the sole discretion of the Authority.
- (d) In the event of an appeal from the award of a Contract, the award shall not be considered final or binding upon the Authority unless the award is thereafter confirmed in writing by the Executive Director.
- (e) For information purposes only, each Applicant should understand that the FTA will not accept any protest or appeal from any decision of the Authority unless the Authority fails to have any written protest procedures, the Authority fails to follow such procedures or the Authority fails to review a timely protest. An Applicant must exhaust all administrative remedies with the Authority before pursuing a protest with FTA. An appeal to FTA must be

received by the appropriate FTA regional or Headquarters Office within five (5) working days of the date the Applicant knew or should have known of the violation.

1.2 Applicant's Identification.

- 1.2.1 Responsible Individuals. Whenever the identification of any individual is required by this RFQ, Applicant shall provide full and complete identification, including the individual's: full name; current address; date of birth; social security number; the full nature and extent of the individual's interest, affiliation, capacity or other relationship with Applicant; the individual's anticipated responsibilities, obligations, liabilities in connection with the Work, the Proposal or the Contract.
- 1.2.2 Other Responsible Persons. Whenever the identification of any Person, other than an individual, is required by this RFQ, the Applicant shall provide full and complete identification, including the Person's: full name and current address; date and place of organization; employer identification number; documentation evidencing organization and authorization to do business in Nebraska; and its anticipated responsibilities, obligations and liabilities in connection with the Work, the Proposal or the Contract.
- 1.2.3 Applicant Identity. Applicant shall identify itself, and all Persons who will act, directly or indirectly, as a Subcontractor in connection with the Work, the Proposal or the Contract. No Subcontractor shall be permitted to perform under the Contract without approval from the Authority, unless so identified.
- 1.2.4 Continued Identity. Applicant shall, in the form of written supplements to its Proposal addressed to the Authority Administrator, keep continuously current through the award of the Contract all information provided pursuant to Section 1.2 of this RFQ, including Sections 1.2.1 and 1.2.2.
- 1.2.5 Designated Recipient of Notice. Applicant shall designate a Person to receive copies of any correspondence, approvals or notice contemplated by the Contract from the Authority. Identification shall include a telephone number, address, telefax number, hours of business and any other information appropriate to enable the Authority to provide any notice.
- 1.2.6 Designated Authorized Representative. Applicant shall identify the individual(s) who shall have authority to bind the Applicant/Contractor in any matter related to the Proposal, Contract or Work.

1.4 Termination.

- 1.4.1 Termination for Convenience by Authority.
 - (a) Any Contract, or any part thereof, awarded by the Authority pursuant to this RFQ shall be subject to termination at any time by the Authority upon notice in writing to be effective as of the date of receipt of such notice. Upon receipt of such notice, Contractor shall, unless otherwise specified in the notice, immediately stop all Work and, to the extent permitted under

each applicable subcontract or agreement, give prompt written notice to Subcontractors to cease all related Work. In the event this Agreement is terminated by application of this Section 1.4., Contractor shall have no claim, right, remedy or entitlement for damages, compensation or equitable relief for early termination other than as provided in Section 1.4.1(b). Contractor waives any other right, remedy or recourse of any nature whatsoever it may have now or at any other time against the Authority and the FTA.

- (b) In the event of termination for convenience pursuant to Section 1.4.1, Authority shall be responsible to pay the Contractor only for all authorized Work performed up to the date of termination and conforming to the Contract, without allocation of profit for unperformed, remaining or incomplete Work. In no event shall the aggregate charges to be paid by Authority pursuant to the preceding sentence exceed resulting from the percentage of the completed Work to that remaining multiplied by the aggregate Contract price. In the event of such termination, Contractor shall have no recourse against Authority except as earlier stated in this Section 1.4.1(b) and as follows: Contractor shall be entitled to receive reimbursement from Authority an amount equal to the sum of: (i) the reasonable out-of-pocket costs actually and necessarily incurred by Contractor in withdrawing its equipment and personnel from the Work and otherwise demobilizing; (ii) the actual, reasonable and necessary costs reasonably incurred by Contractor in terminating those contracts, not assumed by Authority, for Subcontractors; (iii) provided, however, Contractor shall not be paid for any Work after receipt of such notice or for any costs incurred by Subcontractors after receipt of Customer's termination notice, or for Work which Contractor could reasonably have avoided Contractor. Contractor shall document any cost claimed by it to Authority's reasonable satisfaction and shall supply Authority with copies of all invoices for Subcontractors covering the amounts claimed as costs for such purpose. Contractor shall submit an invoice to Authority for the amount of reimbursement claimed by Contractor with all supporting information and requisite documents. Unless disputed in good faith by the Authority, Customer shall be paid such amounts within thirty (30) business days after Customer delivers all Work, completed or not completed, in its then current form, free and clear of all liens and assigns to Authority together with any subcontracts, duly assigned, that Authority is willing to assume.

- 1.4.2 Suspension by Authority. Upon seven (7) days' prior notice, the Authority may suspend, delay, or interrupt for up to six (6) months the Work or the Project for the convenience of the Authority. Nothing in this Section 1.4.2 shall be construed to apply to any such suspension, delay or interruption caused by an event of force majeure (as defined by the Contract Documents). In the event such suspension, delay, or interruption causes a change in Contractor's cost or time required for performance of the Work, the Parties will agree on an equitable adjustment through a written amendment to the Contract to be signed by Authority and Contractor. A suspension may be withdrawn by Authority upon five (5) days' written notice to

Contractor. Any suspension, delay or interruption that exceeds six (6) months shall be deemed to be a termination by Authority and Contractor shall be compensated by Authority as if this were a termination for convenience under Section 1.4.1.

1.4.3 Termination for Default by Authority. Without prejudice to any other remedy or recourse, including its right to seek damages, the Authority may:

- (a) Terminate the Contract effective immediately upon Contractor's receipt of written notice from Authority specifying any of the following events:
 - (i) Insolvency of Contractor.
 - (ii) The filing of a meritorious petition of bankruptcy by or against Contractor or the filing of any petition by Contractor seeking protection under Chapters 7, 11 or 13 of the United States Bankruptcy Code.
 - (iii) The conviction of Contractor of a felony in connection with the Work.
 - (iv) Except as provided in Section 1.4.3(b)(i), the failure to materially comply with any of the Laws.
 - (v) Any attempt to evade any material provision of the Contract or to practice any fraud or deceit upon Authority.
 - (vi) The failure of Contractor or any of its Subcontractor's to fully comply with the lawful directives or cooperate with requests of Authority inspectors or other officials administering or monitoring Work, including any federal, state or other public authority.
 - (viii) Any material misrepresentation by Contractor made at any time.
 - (ix) Contractor improperly assigns or attempts to assign the Contract or any of the Work.
 - (x) The failure to properly maintain, provide or permit Authority access to any books, records, bank accounts or documentation related to the Contract.

- (b) Terminate the Contract, if any of the following (which shall also constitute a material default or breach of the Contract) is not cured to the satisfaction of the Authority within the earlier of thirty (30) days or the time prescribed therefor, in either event from the receipt of written notice from the Authority specifying such breach or default:
 - (i) Contractor fails to conform operations which are in violation of the Laws because of a change in the Laws within 30 days following the effective date of such change.
 - (ii) The failure to promptly pay any sums due to Authority within 5 days of notice.
 - (iii) Contractor refuses or fails to timely commence or perform the Work.
 - (iv) Contractor refuses or fails to supply enough properly skilled workers, or proper materials or Subcontractors to timely perform the Work.

- (v) Contractor fails to comply promptly with rejection notices or notices to correct defects in the Work.
- (vi) Contractor causes or permits any repudiation, lapse or cancellation of performance or other security required by Section 1.1.5.
- (vii) Any other materially breach or default of any covenant, term, condition or provision the Contract, whether or not specified in this Section 1.4.3.

Termination under this Section 1.4.3(b) shall be effective as of the expiration of the period so specified without the necessity of further action by the Authority.

1.4.4 Wrongful Termination by Authority. In the event the Authority shall wrongfully terminate the Contract, unless otherwise agreed by the Parties in writing, to re-instate or otherwise continue the Contract in accordance with its terms, the Authority's termination shall be construed to be a termination for convenience and Section 1.4.1 shall apply.

1.4.5 Future Breach not Waived. No waiver by Authority of any breach or default by Contractor under the Contract shall operate or be construed to operate as a waiver of any other existing or future breach or default, whether of a similar or different character. Failure of the Authority to insist upon strict performance of any provision under this Agreement shall not constitute a waiver of, or estoppel against asserting the right to require strict performance of any other provision of this Agreement or the same provision in the future, nor shall a waiver or estoppel in any one instance constitute a waiver or estoppel with respect to a later default or breach. No waiver by any Person of any default by any Party in the performance of any provision, condition or requirement herein shall be deemed to be a waiver of, or in any manner release of, said Party from performance of any other provision, condition or requirement herein; nor shall such waiver be deemed to be a waiver of, or in any manner a release of, said Party from future performance of the same provision, condition or requirement. Any delay or omission of any Party to exercise any right hereunder shall not impair the exercise of any such right, or any like right, accruing to it thereafter. No waiver of a right created by this Agreement by one or more Parties shall constitute a waiver of such right by the other Parties except as may otherwise be required by law with respect to Persons not parties hereto. The failure of one or more Parties to perform its or their obligations hereunder shall not release the other Parties from the performance of such obligations.

1.4.6 Contractor's Right to Terminate. Contractor shall not be entitled to terminate the Contract for any reason except as provided in this Section 1.4.6. In the event that the Authority fails to timely pay to Contractor any undisputed amounts due pursuant to the terms of the Contract, Authority shall be in default under this Contract and Authority shall be allowed thirty (30) days from receipt of a written notice of such default from Contractor in which to cure such default, after which Seller may immediately terminate this Contract by written notice to Buyer. Any amount disputed by Authority to be due under this Contract must be disputed in good faith.

- 1.4.7 Waiver of Contractor's Other Remedies. Except as provided in Section 1.4.3(b), Contractor waives any claim or other right it may have to proceed in law or equity against Authority or to otherwise obtain any money or any damages under or in respect to this Contract for any wrongful or other termination or for any default or breach in the keeping or performance of any warranty, covenant or obligation under or in respect to this Contract by Authority or for any other act, operation or omission of Authority in respect to the Contract, under any theory whatsoever.
- 1.4.8 Dispute. Continuing Performance. In the event of any dispute between Authority and Contractor with respect to the interpretation of this Contract, any required payment under or the performance required by this Contract, including any dispute which may result in a claim, (a "Dispute"), the aggrieved Party shall notify the other in writing of the Dispute then existing (the "Dispute Notice"). In order for a Party to proceed under this Section, the Dispute Notice must specifically state that the aggrieved Party is invoking the Dispute procedure of this Section 1.4.8. The Parties shall then make a good faith attempt to resolve the Dispute, first through direct discussions between their respective designated representatives. In the event the designated representatives are unable to reach agreement then upon the written request of either Party, each of the Parties will appoint a designated executive whose task it will be to meet for the purpose of endeavoring to resolve such dispute. The designated executives shall meet in Omaha, Nebraska as often as the Parties reasonably deem necessary in order to gather and furnish to the other all information with respect to the matter in issue which the Parties believe to be appropriate and germane in connection with its resolution. Such executives will discuss the problem and/or negotiate in good faith in an effort to resolve the dispute without the necessity of any formal proceeding relating thereto. No action for the resolution of such dispute outside of these procedures shall be taken by either Party until one of the designated executives concludes in good faith that amicable resolution through continued negotiation of the matter in issue does not appear likely and so notifies the other designated executive in writing either party in its sole discretion may invoke litigation, provided that failure to invoke litigation shall not be a waiver of any such Dispute except as otherwise provided in the Contract. During any mediation or litigation which arises out of a Dispute, all parties will continue to perform pursuant to the Contract, without prejudice to the express rights of Authority or Contractor set forth in this Section 1.4 to terminate the Contract. In addition to the specific rights of termination and suspension as set forth in Section 1.4, Authority and Contractor shall have also available the remedy of specific performance to enforce this Section 1.4.8, which may be raised as a defense in any action commenced prior to the Parties' compliance with this Section 1.4.8.

1.5 Warranties of the Parties.

- 1.5.1 Warranties of Applicant/Contractor. In addition to those representations and warranties set forth in the Specifications, or otherwise made in or required by the

Contract, for purposes of its Proposal and the Contract, if awarded to Applicant, Applicant hereby warrants and represents that:

- (a) It is duly organized and existing under and by virtue of the laws of the state of its organization and has the power and authority to own its properties and to carry on the business as presently conducted and as represented and to do business in the State of Nebraska.
- (b) It has all requisite corporate power and authority to execute, deliver and perform the Proposal and Contract; the Proposal and the Contract have been duly authorized, executed and delivered, and as such, constitute its valid and binding obligation, enforceable in accordance with its terms and conditions.
- (c) Performance of the Contract will not violate, or be in conflict with, or result in a material breach of, or constitute a default under, any material agreement, order, judgment, or decree to which it is a party or by which it is bound.
- (d) It has examined or is familiar with all current Laws and shall undertake its performance under the Contract in conformity with the same.
- (e) The representations made in the Contract, including the Certifications made in its Proposal are true, accurate and complete in all respects.
- (f) To the best of its knowledge, after due and diligent inquiry, no elected official of the Authority of Omaha, and no member of the Board of Directors of the Authority nor any the Authority's officers or employees is employed by, or has a financial interest, direct or indirect, in the Contract, the Applicant, the Contractor or any Subcontractors.
- (g) It shall execute and deliver all such other and additional instruments and documents and to do such other acts and things as may be reasonably necessary more fully to effectuate the Work and the Contract. Without limitation to any of the foregoing, all warranties required by the Contract or otherwise applicable to the Work shall be assignable to the Authority upon the completion of the Work or any termination of the Contract.
- (h) In its performance of the Work, Contractor, including its Subcontractors shall use the standard of professional ethics and the degree of skill, care and diligence normally employed by professionals and trades performing the same or similar Work (collectively, the "Standard"). Except as expressly limited by the Specifications, all Work to be furnished under the Contract shall be of highest quality and new, free from faults and defects, suitable for the Authority's purposes and in conformity with the Contract. Any other Work shall be considered defective. Without prejudice to any other recourse available to the Authority, Contractor will re-perform and otherwise remedy any defective Work, including any Work not meeting the Standard without additional compensation.

1.5.2 Warranties of Authority. The Authority makes no representation of any nature to the Applicant, other than that the information provided in this RFQ is true and accurate to the best of its knowledge at the time of its writing.

1.6 Miscellaneous Matters.

- 1.6.1 Severability. The invalidity or unenforceability of any provision of the Contract shall not affect the validity or enforceability of any other provision of the Contract, nor shall the invalidity or unenforceability of a portion of any provision of the Contract affect the validity and enforceability of the balance of such provision. All other provisions and parts of provisions shall remain in full force and effect, provided however, if in the sole opinion of Authority, the removal or inoperative effect of any such provision or part of provision so declared invalid or unenforceable shall materially affect Authority's rights under the Contract, the Authority may terminate the Contract as set forth in Section 1.4.1(a).
- 1.6.2 Time is of Essence in this Agreement. Whenever the Contract shall set forth any time for any action to be performed by or on behalf of the Contractor, time shall be deemed of the essence and as such shall be deemed a material provision of the Contract.
- 1.6.3 Complete Agreement. The Contract constitutes the entire agreement between the Authority and Contractor and supersedes any other agreement or understanding between them. Should the Authority determine that any material provision of the Contract is adversely affected by the subsequent action of the state or federal government (as determined by the Authority in its sole and absolute discretion), the Authority shall have the right to modify the provisions of the Contract to such extent as may be necessary to carry out its original full intent and purpose, otherwise the Contract shall be not be amended or otherwise modified except as required by changes in Law, Sections 1.6.1 or by written mutual agreement of the Parties. All modifications shall be effected by Authority only as permitted by its internal control provisions, which shall be made available from the Grant Administrator. Any amendments or modifications to this Agreement shall be binding upon Contractor's guarantor or surety without notice.
- 1.6.4 Governing Law. The Contract shall be governed by and construed in accordance with the Laws.
- 1.6.5 Venue. With respect to any claim of any Person arising out of the Contract (i) each Party irrevocably submits to the exclusive jurisdiction of the federal courts located in Douglas County in the State of Nebraska (unless such federal courts lack subject matter jurisdiction, in which case each Party irrevocably submits to the exclusive jurisdiction of the State courts located in Douglas County in the State of Nebraska), and (ii) each Party irrevocably waives any objection which it may have at any time to the venue of any suit, action or proceeding arising out of or relating to the Contract brought in any such courts and irrevocably waives any claim that such suit, action or proceeding is brought in an inconvenient forum, and further irrevocably waives the right to object, with respect to such claim, suit or proceeding brought in any such court, that such court does not have jurisdiction over such Party.
- 1.6.6 Assignment. Neither the Contract nor any of Contractor's rights, privileges, liabilities or obligations under the Contract may be assigned, subcontracted (other than to Subcontractors identified in the Proposal) or transferred by Contractor without the prior written consent of the Authority, which may be withheld in its discretion.
- 1.6.7 Survival. All waivers, representations, warranties, indemnities, limitations and remedies provided for in the Contract shall survive the expiration or termination of the Contract.

1.6.8 Notice. Unless otherwise expressly provided in the Contract Documents, any request, protest, notice, response, or approval, required or contemplated by the RFQ or the Contract, shall be considered sufficient only if made in writing and hand-delivered or sent by telephone facsimile or certified or registered mail, postage prepaid to the Person designated below, addressed as follows:

(a) To the Authority:
Grant Administrator
Metro
2222 Cuming Street
Omaha, NE 68102

(b) To the Contractor:
That Person identified in the Proposal for such purposes.
Either party may designate a different Person or address by providing notice of the change to the other.

1.6.9 Requests/Approvals/Consents. Whether or not otherwise so specified in the Contract, all requests and any required consents, notices and approvals shall not be valid unless made in writing.

1.6.10 Headings. The descriptive headings of the Contract are used for convenience only and shall not be deemed to affect the meaning or construction of any such provision.

1.6.11 Relationship of Parties. Nothing in the Contract shall be deemed or construed to create a joint venture, agency or any other relationship by or between the Authority and Contractor other than that of an independent contractor.

1.6.12 Indemnity. For purposes of this Section 1.6.12, "damages" shall mean any and all damages, loss or injury of whatsoever nature, including all claims, demands, suits, proceedings, judgments, recoveries (including any payments by Authority in respect to the foregoing pursuant to a court judgment or good faith settlement by Authority) any fine, penalty, liability, loss, any direct, special, incidental or consequential damages, any damage or injury to Person (including death or bodily injury) or property and causes of action made, asserted, sought or obtained by any private or public third Person from or against, or otherwise sustained by, Authority (including Authority's contractors, employees, licensees, officers, elected or appointed officials and all sums reasonably expended by the Authority for attorney fees in asserting or defending against such damages) whether under theories of breach of contract, tort, negligence, or otherwise. Contractor shall bear sole responsibility and be liable for, and shall hold the Authority harmless and indemnify it from and against, all damages resulting or arising from or out of or in connection with (a) Contractor's operations, including as a result of any act, error or omission of (b) Contractor's and its Subcontractor's (including their respective agents, employees or assigns), performance, non-performance or wrongful performance of or under the Contract or undertaken or made pursuant to the authority of the Contract, (c) any misrepresentation made by Contractor in the Contract Documents, and (d) the breach or default of any warranty. The Authority shall have the right to defend itself (or join in the defense at the cost of Contractor) from and against such

liabilities and damages, unless Contractor fails to promptly or competently undertake defense on behalf of the Authority as required.

- 1.6.13 Contractor's Books and Records. Contractor shall maintain complete and accurate accounting records in accordance with generally accepted accounting practices in connection with all matters related to the Contract and the Work, including to substantiate charges on each invoice. Contractor shall also retain all such records, books, correspondence, instructions, drawings, receipts, subcontracts, agreements, commitments, purchase orders, memoranda, and other data relating to the Contract or the Work normally maintained as part of its established business operations and as may be required by Law. Contractor will permit the Authority and its representatives, at all reasonable times and as otherwise required by the Laws, access to all offices and other facilities and to all such records, to make such reasonable inspections as they may require and will cause its officers promptly to furnish them with such financial and operating data and other information with respect to the business and properties of Contractor relating to the Contract or the Work. Contractor shall preserve all such records for a period required by Law, but in no event less than five (5) years following final payment under the Contract.
- 1.6.14 Change in Work. Authority shall have the right to request Contractor to make reasonable changes to the Work ("Work Change"). Contractor shall consent to make such requested Work Changes, provided that Contractor is technically capable of making such Work Changes, and further provided that: (a) such Work Changes do not materially, individually, or cumulatively increase Contractor's expenses in providing the Work, or (b) if such Work Changes materially increase Contractor's expenses in providing such Work, Contractor agrees to bear the cost for the Work Changes at standard rates in accordance with the Contract Documents.
- 1.6.15 Specific Performance. Each of the Parties recognizes and affirms that in the event of breach by any of them of any of the provisions of this Contract, money damages alone would be inadequate and no adequate remedy at law would exist. Accordingly, each of the Parties agrees that the Authority shall have the right, in addition to any other rights and remedies existing in its favor, to enforce its rights and the obligations of the Contractor under this Contract not only by action or actions for damages, but also by an action or actions for specific performance, injunction and/or other equitable relief in order to enforce or prevent any violations of the provisions of the Contract. In accordance with the above, Contractor waives any claim or defense that the Authority has or may have an adequate remedy at law.

GENERAL REQUIREMENTS

1. Standards of Performance

- 1) Guarantee to perform the Services rendered herein in accordance with the accepted standards of the industry or industries concerned herein, except that if the specifications call for higher standards, then such higher standards shall be provided.
- 2) Upon Metro's Notice of Failure to comply with such standards or to otherwise be in default of the contract in any manner following the Notice to Proceed, the successful respondent(s) shall immediately remedy said defective performance in a manner acceptable to Metro. Should the successful respondent(s) fail to immediately correct said defective performance, said failure shall be considered a breach of the contract and grounds for termination of the same by Metro.

2. In the event of any breach of this contract by the successful respondent(s), the successful respondent(s) shall pay any cost to Metro caused by said breach including but not limited to the replacement cost of such Services with another vendor. Metro reserves the right to withhold **Insurance Requirements**.

Successful respondent(s) may provide the limits of liability required by a combination of the described policy forms and an Umbrella Excess Liability Policy.

- 3) If any or all payments until any defects in performance have been satisfactorily corrected.
- 4) In the event the successful respondent(s) is in breach of this contract in any manner, and such breach has not been satisfactorily corrected, Metro may bar the successful respondent(s) from being awarded any future Metro contracts.
- 5) Concerns - Metro shall cooperate with the Successful respondent to fully explore any concerns regarding performance. In its evaluation of corrective actions, Metro may request the Successful respondent to provide a written explanation of corrective actions corresponding to the implementation dates as determined by Metro. Persistent failure to meet performance expectations as provided in the Contract may lead to the termination of this contract for cause.

3. Safety

- 1) Observe Metro safety policies, pertinent safety practices and comply with any applicable safety regulations.
- 2) Take all precautions necessary for the protection against injury of all persons engaged at all Metro sites in the performance of the contract.
- 3) Be solely and completely responsible for initiating, maintaining and supervising all safety precautions and programs in connection with the work. This requirement will apply continuously and not be limited to normal working hours.

INSURANCE REQUIREMENTS

The requirements identified below shall apply to any Proposal or Contract related to this RFQ. Any Proposal which takes exception to, any such requirement shall be considered non-responsive and will be rejected.

Contractor shall at its own cost and expense procure and maintain those policies of insurance specified in this RFQ throughout the Term and Renewal Term as applicable, of the Contract. All such policies of insurance shall be maintained with responsible insurance carriers licensed to do business in the State of Nebraska and are rated "A" or better by AM Best.

CONTRACTOR'S LIABILITY INSURANCE

The Contractor shall be required to have in continuous effect insurance written for not less than the following, or greater if required by law:

- a) **Commercial General Liability Insurance** including Personal Injury Liability, Independent Contractor's Liability, Contractual Liability, Product Liability, and Completed Operations Liability.

Limits

\$2,000,000 General Aggregate Limit
\$1,000,000 Products/Completed Work Limit
\$1,000,000 Personal/Advertising Injury Limit
\$1,000,000 Each Occurrence Limit
\$500,000 Fire Damage Limit (any one fire)
\$5,000 Medical Payments Limit (any one person)

- b) **Business Automobile Liability Insurance**

- Combined Single Limit \$1,000,000 Each Occurrence

- c) **Excess Liability, Umbrella Insurance Form**

- Limits
(BI and PD combined) - \$2,000,000
Each Occurrence Limit - \$2,000,000
General Aggregate Limit - \$2,000,000
Products/Completed Work Limit - \$2,000,000

- d) **Workers Compensation and Employer's Liability**

- State Statutory Limits

The Contractor may provide the limits of liability required above by a combination of the above-described policy forms. Consult your insurance agent for details.

Evidence of Coverage

All insurance required herein shall contain a waiver of subrogation in favor of Metro and shall name Metro as additional insured (except Workers Compensation) and shall specify that in the event of

cancellation or material change in coverage, at least thirty (30) days prior notice will be given to Metro concerning such event. The contractor must furnish Metro with certificates of insurance as evidence of satisfaction of the above insurance requirements within 10 business days after receipt of the Notice to Proceed. Failure to comply shall result in Termination for Default by Metro.

LABOR AND MATERIAL PAYMENT BOND

1. Pursuant to Nebraska State Statute 52-118, as revised, the successful bidder shall furnish a Payment Bond, in the amount of 100% of the contracted amount. This Bond will be written by a surety licensed to do business in the State of Nebraska, and who is acceptable to the Authority.
2. The bidder shall deliver the required bond to the Authority no later than the date of execution of the contract, or if the work commenced prior thereto in response to a letter of intent, the bidders shall, prior to the commencement of the work, submit evidence satisfactory to the Authority that such bond will be furnished.

**APPENDIX B
REQUEST FOR CLARIFICATION OR SUBSTITUTION**

Project: Exterior Repair – Sidewalk Repair

Date _____

Project No. NE-90-X104

Specification No. 14-16

Request for Clarifications/Substitutions

Project Title: _____ Date: _____

Company Name: _____ Page No: _____

Document Reference (check one):

General Requirements: _____ Specifications: _____

Section Number: _____

Section Title: _____

BIDDER'S REQUEST:

METRO RESPONSE:

Approved _____

Denied _____

Metro Comments:

Metro Authorized Signature

Date of Response

Grant Administrator

Metro Transit, 2222 Cuming Street, Omaha, NE 68102 jrumery@ometro.com

**EXHIBIT C
ACKNOWLEDGMENT OF ADDENDA**

Project: Exterior Repair – Sidewalk Repair

Date _____

Project No. NE-90-X104

Specification No. 14-16

In submitting this Bid, I hereby acknowledge receipt of addendum # ____ through ____.

Print Name of Firm

Print Name of Authorized Representative

Print Email Address

Print Title of Authorized Representative

Print Street Address / Mailing Address

Area Code & Telephone Number

Area Code & Fax Number

Signature of Authorized Representative

This form must be signed and submitted in bid package. All signatures must be original.

**FEDERAL CLAUSES FOR PROCUREMENT OF CONSTRUCTION
(Attachment 1)**

NO OBLIGATION BY THE FEDERAL GOVERNMENT

The Purchaser and Contractor acknowledge and agree that, notwithstanding any concurrence by the Federal Government in or approval of the solicitation or award of the underlying contract, absent the express written consent by the Federal Government, the Federal Government is not a party to this contract and shall not be subject to any obligations or liabilities to the Purchaser, Contractor, or any other party (whether or not a party to that contract) pertaining to any matter resulting from the underlying contract.

The Contractor agrees to include the above clause in each subcontract financed in whole or in part with Federal assistance provided by FTA. It is further agreed that the clause shall not be modified, except to identify the subcontractor who will be subject to its provisions.

PROGRAM FRAUD AND FALSE OR FRAUDULENT STATEMENTS OR RELATED ACTS

The Contractor acknowledges that the provisions of the Program Fraud Civil Remedies Act of 1986, as amended, 31 U.S.C. § § 3801 et seq. and U.S. DOT regulations, "Program Fraud Civil Remedies," 49 C.F.R. Part 31, apply to its actions pertaining to this Project. Upon execution of the underlying contract, the Contractor certifies or affirms the truthfulness and accuracy of any statement it has made, it makes, it may make, or causes to be made, pertaining to the underlying contract or the FTA assisted project for which this contract work is being performed. In addition to other penalties that may be applicable, the Contractor further acknowledges that if it makes, or causes to be made, a false, fictitious, or fraudulent claim, statement, submission, or certification, the Federal Government reserves the right to impose the penalties of the Program Fraud Civil Remedies Act of 1986 on the Contractor to the extent the Federal Government deems appropriate.

The Contractor also acknowledges that if it makes, or causes to be made, a false, fictitious, or fraudulent claim, statement, submission, or certification to the Federal Government under a contract connected with a project that is financed in whole or in part with Federal assistance originally awarded by FTA under the authority of 49 U.S.C. § 5307, the Government reserves the right to impose the penalties of 18 U.S.C. § 1001 and 49 U.S.C. § 5307(n)(1) on the Contractor, to the extent the Federal Government deems appropriate.

The Contractor agrees to include the above two clauses in each subcontract financed in whole or in part with Federal assistance provided by FTA. It is further agreed that the clauses shall not be modified, except to identify the subcontractor who will be subject to the provisions.

ACCESS TO RECORDS

Where the Purchaser enters into a negotiated contract for other than a small purchase or under the simplified acquisition threshold and is an institution of higher education, a hospital or other non-profit organization and is the FTA Recipient or a sub-grantee of the FTA Recipient in accordance with 49 C.F.R. 19.48, Contractor agrees to provide the Purchaser, FTA Administrator, the Comptroller General of the United States or any of their duly authorized representatives with access to any books, documents, papers and record of the Contractor which are directly pertinent to this contract for the purposes of making audits, examinations, excerpts and transcriptions.

Where any Purchaser which is the FTA Recipient or a sub-grantee of the FTA Recipient in accordance with 49 U.S.C. 5325(a) enters into a contract for a capital project or improvement (defined at 49 U.S.C. 5302(a)1) through other than competitive bidding, the Contractor shall make available records related to the contract to the Purchaser, the Secretary of Transportation and the Comptroller General or any authorized officer or employee of any of them for the purposes of conducting an audit and inspection.

The Contractor agrees to permit any of the foregoing parties to reproduce by any means whatsoever or to copy excerpts and transcriptions as reasonably needed.

The Contractor agrees to maintain all books, records, accounts and reports required under this contract for a period of not less than three years after the date of termination or expiration of this contract, except in the event of litigation or settlement of claims arising from the performance of this contract, in which case Contractor agrees to maintain same until the Purchaser, the FTA Administrator, the Comptroller General, or any of their duly authorized representatives, have disposed of all such litigation, appeals, claims or exceptions related thereto. Reference 49 CFR 18.39(i)(11).

FTA does not require the inclusion of these requirements in subcontracts.

FEDERAL CHANGES

Contractor shall at all times comply with all applicable FTA regulations, policies, procedures and directives, including without limitation those listed directly or by reference in the current Master Agreement between Purchaser and FTA, as they may be amended or promulgated from time to time during the term of this contract. Contractor's failure to so comply shall constitute a material breach of this contract.

CIVIL RIGHTS

Nondiscrimination - In accordance with Title VI of the Civil Rights Act, as amended, 42 U.S.C. § 2000d, section 303 of the Age Discrimination Act of 1975, as amended, 42 U.S.C. § 6102, section 202 of the Americans with Disabilities Act of 1990, 42 U.S.C. § 12132, and Federal transit law at 49 U.S.C. § 5332, the Contractor agrees that it will not discriminate against any employee or applicant for employment because of race, color, creed, national origin, sex, age, or disability. In addition, the Contractor agrees to comply with applicable Federal implementing regulations and other implementing requirements FTA may issue.

Equal Employment Opportunity; Race, Color, Creed, Religion, Sex (including pregnancy), Mental/Physical Disability, Age (40 or over), National Origin, Genetic Information or any other basis prohibited by law - In accordance with Title VII of the Civil Rights Act, as amended, 42 U.S.C. § 2000e, and Federal transit laws at 49 U.S.C. § 5332, the Contractor agrees to comply with all applicable equal employment opportunity requirements of U.S. Department of Labor (U.S. DOL) regulations, "Office of Federal Contract Compliance Programs, Equal Employment Opportunity, Department of Labor," 41 C.F.R. Parts 60 et seq ., (which implement Executive Order No. 11246, "Equal Employment Opportunity," as amended by Executive Order No. 11375, "Amending Executive Order 11246 Relating to Equal Employment Opportunity," 42 U.S.C. § 2000e note), and with any applicable Federal statutes, executive orders, regulations, and Federal policies that may in the future affect construction activities undertaken in the course of the Project. The Contractor agrees

to take affirmative action to ensure that applicants are employed, and that employees are treated during employment, without regard to their race, color, creed, national origin, sex, or age. Such action shall include, but not be limited to, the following: employment, upgrading, demotion or transfer, recruitment or recruitment advertising, layoff or termination; rates of pay or other forms of compensation; and selection for training, including apprenticeship. In addition, the Contractor agrees to comply with any implementing requirements FTA may issue.

Age - In accordance with section 4 of the Age Discrimination in Employment Act of 1967, as amended, 29 U.S.C. § § 623 and Federal transit law at 49 U.S.C. § 5332, the Contractor agrees to refrain from discrimination against present and prospective employees for reason of age. In addition, the Contractor agrees to comply with any implementing requirements FTA may issue.

ADA - In accordance with section 102 of the Americans with Disabilities Act, as amended, 42 U.S.C. § 12112, the Contractor agrees that it will comply with the requirements of U.S. Equal Employment Opportunity Commission, "Regulations to Implement the Equal Employment Provisions of the Americans with Disabilities Act," 29 C.F.R. Part 1630, pertaining to employment of persons with disabilities. In addition, the Contractor agrees to comply with any implementing requirements FTA may issue.

The Contractor also agrees to include these requirements in each subcontract financed in whole or in part with Federal assistance provided by FTA, modified only if necessary to identify the affected parties.

DISADVANTAGED BUSINESS ENTERPRISE (DBE)

The Transit Authority of the City of Omaha d/b/a Metro has established a Disadvantaged Business Enterprise (DBE) program in accordance with regulations of the U.S. Department of Transportation (DOT), 49 CFR Part 26. Metro has received Federal financial assistance from the Department of Transportation, and as a condition of receiving this assistance, Metro has signed an assurance that it will comply with 49 CFR Part 26.

It is the policy of Metro to ensure that DBEs as defined in part 26, have an equal opportunity to receive and participate in DOT–assisted contracts. It is also our policy:

- To ensure nondiscrimination in the award and administration of DOT-assisted contracts;
- To create a level playing field on which DBEs can compete fairly for DOT-assisted contracts;
- To ensure that the DBE Program is narrowly tailored in accordance with applicable law;
- To ensure that only firms that fully meet 49 CFR Part 26 eligibility standards are permitted to participate as DBEs;
- To help remove barriers to the participation of DBEs in DOT-assisted contracts;
- To assist the development of firms that can compete successfully in the market place outside the DBE Program.

Director of Legal/Human Resources has been delegated as the DBE Liaison Officer. In that capacity, the Director of Administration/Human Resources is responsible for implementing all aspects of the

DBE program. Implementation of the DBE program is accorded the same priority as compliance with all other legal obligations incurred by Metro in its financial assistance agreements with the Department of Transportation.

The Metro Board of Directors has adopted a formal Operating Policy demonstrating the company's commitment to implementing all aspects of the DBE program which has been disseminated to managers and officials responsible for procurement of goods and services. The Policy Statement is posted on company Bulletin Boards. We have distributed this statement to DBE and non-DBE business communities that perform work for us on DOT-assisted contracts by posting the statement on the company's website and including the Statement of Policy in solicitation documents.

The (Contractor, Sub-recipient, or Sub-contractor) shall not discriminate on the basis of race, color, national origin, or sex in the performance of the (Contract or Agreement). The requirements of 49 C.F.R. Part 26 or at another Part if reissued and the Recipient's U.S. DOT-Approved Disadvantaged Business Enterprise (DBE) Program (where required) are incorporated in this (Contract or Agreement) by reference. Failure by the (Contractor, Sub-recipient, or Sub-contractor) to carry out these requirements is a material breach of the (Contract or Agreement), which may result in the termination of the (Contract or Agreement) or such other remedy as the Recipient deems appropriate.

The prime contractor agrees to pay each sub-contractor under this prime contract for satisfactory performance of its contract within thirty (30) days following satisfactory performance of the sub-contractor's work. The prime contractor further agrees to return any retainage payments to each subcontractor within thirty (30) days upon satisfactory completion of the sub-contractor's work. Any delay or postponement of payment may occur only for good cause following written approval of Metro. This clause applies to both DBE and non-DBE sub-contractors.

INCORPORATION OF FEDERAL TRANSIT ADMINISTRATION (FTA) TERMS

The preceding provisions include, in part, certain Standard Terms and Conditions required by DOT, whether or not expressly set forth in the preceding contract provisions. All contractual provisions required by DOT, as set forth in FTA Circular 4220.1E dated June 19, 2003, are hereby incorporated by reference. Anything to the contrary herein notwithstanding, all FTA mandated terms shall be deemed to control in the event of a conflict with other provisions contained in this Agreement. The Contractor shall not perform any act, fail to perform any act, or refuse to comply with any of The Authorities requests, which would cause The Authority to be in violation of the FTA terms and conditions.

ENERGY CONSERVATION

The contractor agrees to comply with mandatory standards and policies relating to energy efficiency which are contained in the state energy conservation plan issued in compliance with the Energy Policy and Conservation Act.

STATE AND LOCAL LAW DISCLAIMER

All regulations listed in this document apply to the Third Party Contractor in the same manner as they apply to The Authority. Offers will be received and reviewed, but no contract shall be awarded until all applicable Federal, State and Local Government regulations have been complied with.

ADA ACCESS

The contractor agrees to comply with the requirements of 49 U.S.C. § 5301 (d), which states the Federal policy that the elderly and persons with disabilities have the same right as other persons to use mass transportation service and facilities, and that special efforts shall be made in planning and designing those services and facilities to implement that policy. The contractor also agrees to comply with all applicable requirements of section 504 of the Rehabilitation Act of 1973, as amended, 29 U.S.C. § 794, which prohibits discrimination on the basis of handicaps, with the Americans with Disabilities Act of 1990 (ADA), as amended, 42 U.S.C. §§ 12101 *et seq.*, which requires that accessible facilities and services be made available to persons with disabilities, including any subsequent amendments to that Act, and with the Architectural Barriers act of 1968, as amended, 42 U.S.C. §§ 4151 *et seq.*, which requires that buildings and public accommodations be accessible to persons with disabilities, including any subsequent amendments to that Act. In addition, the contractor agrees to comply with any and all applicable requirements issued by the FTA, DOT, DOJ, U.S. GSA, U.S. EEOC, U.S. FCC, any subsequent amendments thereto and any other nondiscrimination statute(s) that may apply to the Project.

CONTRACT WORK HOURS AND SAFETY STANDARDS ACT

Overtime requirements - No contractor or subcontractor contracting for any part of the contract work which may require or involve the employment of laborers or mechanics shall require or permit any such laborer or mechanic in any workweek in which he or she is employed on such work to work in excess of forty hours in such workweek unless such laborer or mechanic receives compensation at a rate not less than one and one-half times the basic rate of pay for all hours worked in excess of forty hours in such workweek.

Violation; liability for unpaid wages; liquidated damages - In the event of any violation of the clause set forth in paragraph (1) of this section the contractor and any subcontractor responsible therefor shall be liable for the unpaid wages. In addition, such contractor and subcontractor shall be liable to the United States for liquidated damages. Such liquidated damages shall be computed with respect to each individual laborer or mechanic, including watchmen and guards, employed in violation of the clause set forth in paragraph (1) of this section, in the sum of \$ 10 for each calendar day on which such individual was required or permitted to work in excess of the standard workweek of forty hours without payment of the overtime wages required by the clause set forth in paragraph.

Withholding for unpaid wages and liquidated damages - The Authority shall upon its own action or upon written request of an authorized representative of the Department of Labor withhold or cause to be withheld, from any moneys payable on account of work performed by the contractor or subcontractor under any such contract or any other Federal contract with the same prime contractor, or any other federally-assisted contract subject to the Contract Work Hours and Safety Standards Act, which is held by the same prime contractor, such sums as may be determined to be necessary to satisfy any liabilities of such contractor or subcontractor for unpaid wages and liquidated damages as provided in the clause set forth in paragraph (2) of this section.

Subcontracts - The contractor or subcontractor shall insert in any subcontracts the clauses set forth in this section and also a clause requiring the subcontractors to include these clauses in any lower tier subcontracts. The prime contractor shall be responsible for compliance by any subcontractor or lower tier subcontractor with the clauses set forth in this section.

Payrolls and basic records - (i) Payrolls and basic records relating thereto shall be maintained by the contractor during the course of the work and preserved for a period of three years thereafter for all laborers and mechanics working at the site of the work (or under the United States Housing Act of 1937, or under the Housing Act of 1949, in the construction or development of the project). Such records shall contain the name, address, and social security number of each such worker, his or her correct classification, hourly rates of wages paid (including rates of contributions or costs anticipated for bona fide fringe benefits or cash equivalents thereof of the types described in section 1(b)(2)(B) of the Davis-Bacon Act), daily and weekly number of hours worked, deductions made and actual wages paid. Whenever the Secretary of Labor has found under 29 CFR 5.5(a)(1)(iv) that the wages of any laborer or mechanic include the amount of any costs reasonably anticipated in providing benefits under a plan or program described in section 1(b)(2)(B) of the Davis-Bacon Act, the contractor shall maintain records which show that the commitment to provide such benefits is enforceable, that the plan or program is financially responsible, and that the plan or program has been communicated in writing to the laborers or mechanics affected, and records which show the costs anticipated or the actual cost incurred in providing such benefits. Contractors employing apprentices or trainees under approved programs shall maintain written evidence of the registration of apprenticeship programs and certification of trainee programs, the registration of the apprentices and trainees, and the ratios and wage rates prescribed in the applicable programs.

Contract Work Hours and Safety Standards Act - (i) The Contractor agrees to comply with section 107 of the Contract Work Hours and Safety Standards Act, 40 U.S.C. section 333, and applicable DOL regulations, " Safety and Health Regulations for Construction " 29 C.F.R. Part 1926. Among other things, the Contractor agrees that it will not require any laborer or mechanic to work in unsanitary, hazardous, or dangerous surroundings or working conditions.

Subcontracts - The Contractor also agrees to include the requirements of this section in each subcontract. The term "subcontract" under this section is considered to refer to a person who agrees to perform any part of the labor or material requirements of a contract for construction, alteration or repair. A person who undertakes to perform a portion of a contract involving the furnishing of supplies or materials will be considered a "subcontractor" under this section if the work in question involves the performance of construction work and is to be performed: (1) directly on or near the construction site, or (2) by the employer for the specific project on a customized basis. Thus, a supplier of materials which will become an integral part of the construction is a "subcontractor" if the supplier fabricates or assembles the goods or materials in question specifically for the construction project and the work involved may be said to be construction activity. If the goods or materials in question are ordinarily sold to other customers from regular inventory, the supplier is not a "subcontractor." The requirements of this section do not apply to contracts or subcontracts for the purchase of supplies or materials or articles normally available on the open market.

RECYCLED PRODUCTS

These requirements apply to contractors and sub-contractors at all tiers. The Recycled Products requirements apply to all contracts for items designated by the EPA, when the purchaser or contractor procures \$10,000 or more of one of these items during the fiscal year, or has procured \$10,000 or more of such items in the previous fiscal year, using Federal funds.

The contractor agrees to comply with all the requirements of Section 6002 of the Resource Conservation and Recovery Act (RCRA), as amended (42 U.S.C. 6962), including but not limited to

the regulatory provisions of 40 CFR Part 247, and Executive Order 12873, as they apply to the procurement of the items designated in Subpart B of 40 CFR Part 247.

SEISMIC SAFETY

The contractor agrees that any new building or addition to an existing building will be designed and constructed in accordance with the standards for Seismic Safety required in Department of Transportation Seismic Safety Regulations 49 CFR Part 41 and will certify to compliance to the extent required by the regulation. The contractor also agrees to ensure that all work performed under this contract including work performed by a subcontractor is in compliance with the standards required by the Seismic Safety Regulations and the certification of compliance issued on the project.

DAVIS-BACON ACT

Minimum wages

All laborers and mechanics employed or working upon the site of the work (or under the United States Housing Act of 1937 or under the Housing Act of 1949 in the construction or development of the project), will be paid unconditionally and not less often than once a week, and without subsequent deduction or rebate on any account (except such payroll deductions as are permitted by regulations issued by the Secretary of Labor under the Copeland Act (29 CFR part 3)), the full amount of wages and bona fide fringe benefits (or cash equivalents thereof) due at time of payment computed at rates not less than those contained in the wage determination of the Secretary of Labor which is attached hereto and made a part hereof, regardless of any contractual relationship which may be alleged to exist between the contractor and such laborers and mechanics.

Contributions made or costs reasonably anticipated for bona fide fringe benefits under section 1(b)(2) of the Davis-Bacon Act on behalf of laborers or mechanics are considered wages paid to such laborers or mechanics, subject to the provisions of this section; also, regular contributions made or costs incurred for more than a weekly period (but not less often than quarterly) under plans, funds, or programs which cover the particular weekly period, are deemed to be constructively made or incurred during such weekly period. Such laborers and mechanics shall be paid the appropriate wage rate and fringe benefits on the wage determination for the classification of work actually performed, without regard to skill, except as provided in 29 CFR Part 5.5(a)(4). Laborers or mechanics performing work in more than one classification may be compensated at the rate specified for each classification for the time actually worked therein: Provided, That the employer's payroll records accurately set forth the time spent in each classification in which work is performed. The wage determination and the Davis-Bacon poster (WH-1321) shall be posted at all times by the contractor and its subcontractors at the site of the work in a prominent and accessible place where the workers can easily see it.

The contracting officer shall require that any class of laborers or mechanics, including helpers, which is not listed in the wage determination and which is to be employed under the contract shall be classified in conformance with the wage determination. The contracting officer shall approve an additional classification and wage rate and fringe benefits therefore only when the following criteria have been met:

- Except with respect to helpers as defined as 29 CFR 5.2(n)(4), the work to be performed by the classification requested is not performed by a classification in the wage determination; and

- The classification is utilized in the area by the construction industry; and
- The proposed wage rate, including any bona fide fringe benefits, bears a reasonable relationship to the wage rates contained in the wage determination; and
- With respect to helpers as defined in 29 CFR 5.2(n)(4), such a classification prevails in the area in which the work is performed.

If the contractor and the laborers and mechanics to be employed in the classification (if known), or their representatives, and the contracting officer agree on the classification and wage rate (including the amount designated for fringe benefits where appropriate), a report of the action taken shall be sent by the contracting officer to the Administrator of the Wage and Hour Division, Employment Standards Administration, U.S. Department of Labor, Washington, DC 20210. The Administrator, or an authorized representative, will approve, modify, or disapprove every additional classification action within 30 days of receipt and so advise the contracting officer or will notify the contracting officer within the 30-day period that additional time is necessary.

In the event the contractor, the laborers or mechanics to be employed in the classification or their representatives, and the contracting officer do not agree on the proposed classification and wage rate (including the amount designated for fringe benefits, where appropriate), the contracting officer shall refer the questions, including the views of all interested parties and the recommendation of the contracting officer, to the Administrator for determination. The Administrator, or an authorized representative, will issue a determination within 30 days of receipt and so advise the contracting officer or will notify the contracting officer within the 30-day period that additional time is necessary.

The wage rate (including fringe benefits where appropriate) determined pursuant to this section, shall be paid to all workers performing work in the classification under this contract from the first day on which work is performed in the classification.

Whenever the minimum wage rate prescribed in the contract for a class of laborers or mechanics includes a fringe benefit which is not expressed as an hourly rate, the contractor shall either pay the benefit as stated in the wage determination or shall pay another bona fide fringe benefit or an hourly cash equivalent thereof.

If the contractor does not make payments to a trustee or other third person, the contractor may consider as part of the wages of any laborer or mechanic the amount of any costs reasonably anticipated in providing bona fide fringe benefits under a plan or program, Provided, That the Secretary of Labor has found, upon the written request of the contractor, that the applicable standards of the Davis-Bacon Act have been met. The Secretary of Labor may require the contractor to set aside in a separate account assets for the meeting of obligations under the plan or program.

The contracting officer shall require that any class of laborers or mechanics which is not listed in the wage determination and which is to be employed under the contract shall be classified in conformance with the wage determination. The contracting officer shall approve an additional classification and wage rate and fringe benefits therefor only when the following criteria have been met:

- (1) The work to be performed by the classification requested is not performed by a classification in the wage determination; and
- (2) The classification is utilized in the area by the construction industry; and
- (3) The proposed wage rate, including any bona fide fringe benefits, bears a reasonable relationship to the wage rates contained in the wage determination.

If the contractor and the laborers and mechanics to be employed in the classification (if known), or their representatives, and the contracting officer agree on the classification and wage rate (including the amount designated for fringe benefits where appropriate), a report of the action taken shall be sent by the contracting officer to the Administrator of the Wage and Hour Division, Employment Standards Administration, Washington, DC 20210. The Administrator, or an authorized representative, will approve, modify, or disapprove every additional classification action within 30 days of receipt and so advise the contracting officer or will notify the contracting officer within the 30-day period that additional time is necessary.

In the event the contractor, the laborers or mechanics to be employed in the classification or their representatives, and the contracting officer do not agree on the proposed classification and wage rate (including the amount designated for fringe benefits, where appropriate), the contracting officer shall refer the questions, including the views of all interested parties and the recommendation of the contracting officer, to the Administrator for determination. The Administrator, or an authorized representative, will issue a determination with 30 days of receipt and so advise the contracting officer or will notify the contracting officer within the 30-day period that additional time is necessary.

The wage rate (including fringe benefits where appropriate) determined pursuant to paragraphs (a)(1)(v) (B) or (C) of this section, shall be paid to all workers performing work in the classification under this contract from the first day on which work is performed in the classification.

Withholding

The Authority shall upon its own action or upon written request of an authorized representative of the Department of Labor withhold or cause to be withheld from the contractor under this contract or any other Federal contract with the same prime contractor, or any other federally-assisted contract subject to Davis-Bacon prevailing wage requirements, which is held by the same prime contractor, so much of the accrued payments or advances as may be considered necessary to pay laborers and mechanics, including apprentices, trainees, and helpers, employed by the contractor or any subcontractor the full amount of wages required by the contract. In the event of failure to pay any laborer or mechanic, including any apprentice, trainee, or helper, employed or working on the site of the work (or under the United States Housing Act of 1937 or under the Housing Act of 1949 in the construction or development of the project), all or part of the wages required by the contract, The Authority may, after written notice to the contractor, sponsor, applicant, or owner, take such action as may be necessary to cause the suspension of any further payment, advance, or guarantee of funds until such violations have ceased.

Payrolls and basic records

Payrolls and basic records relating thereto shall be maintained by the contractor during the course of the work and preserved for a period of three years thereafter for all laborers and mechanics

working at the site of the work (or under the United States Housing Act of 1937, or under the Housing Act of 1949, in the construction or development of the project). Such records shall contain the name, address, and social security number of each such worker, his or her correct classification, hourly rates of wages paid (including rates of contributions or costs anticipated for bona fide fringe benefits or cash equivalents thereof of the types described in section 1(b)(2)(B) of the Davis-Bacon Act), daily and weekly number of hours worked, deductions made and actual wages paid. Whenever the Secretary of Labor has found under 29 CFR 5.5(a)(1)(iv) that the wages of any laborer or mechanic include the amount of any costs reasonably anticipated in providing benefits under a plan or program described in section 1(b)(2)(B) of the Davis-Bacon Act, the contractor shall maintain records which show that the commitment to provide such benefits is enforceable, that the plan or program is financially responsible, and that the plan or program has been communicated in writing to the laborers or mechanics affected, and records which show the costs anticipated or the actual cost incurred in providing such benefits. Contractors employing apprentices or trainees under approved programs shall maintain written evidence of the registration of apprenticeship programs and certification of trainee programs, the registration of the apprentices and trainees, and the ratios and wage rates prescribed in the applicable programs.

The contractor shall submit weekly for each week in which any contract work is performed a copy of all payrolls to The Authority for transmission to the Federal Transit Administration. The payrolls submitted shall set out accurately and completely all of the information required to be maintained under 29 CFR part 5. This information may be submitted in any form desired. Optional Form WH-347 is available for this purpose and may be purchased from the Superintendent of Documents (Federal Stock Number 029-005-00014-1), U.S. Government Printing Office, Washington, DC 20402. The prime contractor is responsible for the submission of copies of payrolls by all subcontractors.

Each payroll submitted shall be accompanied by a "Statement of Compliance," signed by the contractor or subcontractor or his or her agent who pays or supervises the payment of the persons employed under the contract and shall certify the following:

- (1) That the payroll for the payroll period contains the information required to be maintained under 29 CFR part 5 and that such information is correct and complete;
 - (2) That each laborer or mechanic (including each helper, apprentice, and trainee) employed on the contract during the payroll period has been paid the full weekly wages earned, without rebate, either directly or indirectly, and that no deductions have been made either directly or indirectly from the full wages earned, other than permissible deductions as set forth in Regulations, 29 CFR part 3;
 - (3) That each laborer or mechanic has been paid not less than the applicable wage rates and fringe benefits or cash equivalents for the classification of work performed, as specified in the applicable wage determination incorporated into the contract.
- (b) The weekly submission of a properly executed certification set forth on the reverse side of Optional Form WH-347 shall satisfy the requirement for submission of the "Statement of Compliance" required by this section.

- (c) The falsification of any of the above certifications may subject the contractor or subcontractor to civil or criminal prosecution under section 1001 of title 18 and section 231 of title 31 of the United States Code.

The contractor or subcontractor shall make the records required under this section available for inspection, copying, or transcription by authorized representatives of the Federal Transit Administration or the Department of Labor, and shall permit such representatives to interview employees during working hours on the job. If the contractor or subcontractor fails to submit the required records or to make them available, the Federal agency may, after written notice to the contractor, sponsor, applicant, or owner, take such action as may be necessary to cause the suspension of any further payment, advance, or guarantee of funds. Furthermore, failure to submit the required records upon request or to make such records available may be grounds for debarment action pursuant to 29 CFR 5.12.

Apprentices and Trainees

Apprentices - Apprentices will be permitted to work at less than the predetermined rate for the work they performed when they are employed pursuant to and individually registered in a bona fide apprenticeship program registered with the U.S. Department of Labor, Employment and Training Administration, Bureau of Apprenticeship and Training, or with a State Apprenticeship Agency recognized by the Bureau, or if a person is employed in his or her first 90 days of probationary employment as an apprentice in such an apprenticeship program, who is not individually registered in the program, but who has been certified by the Bureau of Apprenticeship and Training or a State Apprenticeship Agency (where appropriate) to be eligible for probationary employment as an apprentice. The allowable ratio of apprentices to journeymen on the job site in any craft classification shall not be greater than the ratio permitted to the contractor as to the entire work force under the registered program. Any worker listed on a payroll at an apprentice wage rate, who is not registered or otherwise employed as stated above, shall be paid not less than the applicable wage rate on the wage determination for the classification of work actually performed. In addition, any apprentice performing work on the job site in excess of the ratio permitted under the registered program shall be paid not less than the applicable wage rate on the wage determination for the work actually performed. Where a contractor is performing construction on a project in a locality other than that in which its program is registered, the ratios and wage rates (expressed in percentages of the journeyman's hourly rate) specified in the contractor's or subcontractor's registered program shall be observed. Every apprentice must be paid at not less than the rate specified in the registered program for the apprentice's level of progress, expressed as a percentage of the journeymen hourly rate specified in the applicable wage determination. Apprentices shall be paid fringe benefits in accordance with the provisions of the apprenticeship program. If the apprenticeship program does not specify fringe benefits, apprentices must be paid the full amount of fringe benefits listed on the wage determination for the applicable classification. If the Administrator of the Wage and Hour Division of the U.S. Department of Labor determines that a different practice prevails for the applicable apprentice classification, fringes shall be paid in accordance with that determination. In the event the Bureau of Apprenticeship and Training, or a State Apprenticeship Agency recognized by the Bureau, withdraws approval of an apprenticeship program, the contractor will no longer be permitted to utilize apprentices at less than the applicable predetermined rate for the work performed until an acceptable program is approved.

Trainees - Except as provided in 29 CFR 5.16, trainees will not be permitted to work at less than the predetermined rate for the work performed unless they are employed pursuant to and individually

registered in a program which has received prior approval, evidenced by formal certification by the U.S. Department of Labor, Employment and Training Administration. The ratio of trainees to journeymen on the job site shall not be greater than permitted under the plan approved by the Employment and Training Administration. Every trainee must be paid at not less than the rate specified in the approved program for the trainee's level of progress, expressed as a percentage of the journeyman hourly rate specified in the applicable wage determination. Trainees shall be paid fringe benefits in accordance with the provisions of the trainee program. If the trainee program does not mention fringe benefits, trainees shall be paid the full amount of fringe benefits listed on the wage determination unless the Administrator of the Wage and Hour Division determines that there is an apprenticeship program associated with the corresponding journeyman wage rate on the wage determination which provides for less than full fringe benefits for apprentices. Any employee listed on the payroll at a trainee rate who is not registered and participating in a training plan approved by the Employment and Training Administration shall be paid not less than the applicable wage rate on the wage determination for the classification of work actually performed. In addition, any trainee performing work on the job site in excess of the ratio permitted under the registered program shall be paid not less than the applicable wage rate on the wage determination for the work actually performed. In the event the Employment and Training Administration withdraws approval of a training program, the contractor will no longer be permitted to utilize trainees at less than the applicable predetermined rate for the work performed until an acceptable program is approved.

Equal employment opportunity - The utilization of apprentices, trainees and journeymen under this part shall be in conformity with the equal employment opportunity requirements of Executive Order 11246, as amended, and 29 CFR part 30.

Compliance with Copeland Act requirements - The contractor shall comply with the requirements of 29 CFR part 3, which are incorporated by reference in this contract.

Subcontracts - The contractor or subcontractor shall insert in any subcontracts the clauses contained in 29 CFR 5.5(a)(1) through (10) and such other clauses as the Federal Transit Administration may by appropriate instructions require, and also a clause requiring the subcontractors to include these clauses in any lower tier subcontracts. The prime contractor shall be responsible for the compliance by any subcontractor or lower tier subcontractor with all the contract clauses in 29 CFR 5.5.

Contract termination: debarment - A breach of the contract clauses in 29 CFR 5.5 may be grounds for termination of the contract, and for debarment as a contractor and a subcontractor as provided in 29 CFR 5.12.

Compliance with Davis-Bacon and Related Act requirements - All rulings and interpretations of the Davis-Bacon and Related Acts contained in 29 CFR parts 1, 3, and 5 are herein incorporated by reference in this contract.

Disputes concerning labor standards - Disputes arising out of the labor standards provisions of this contract shall not be subject to the general dispute clause of this contract. Such disputes shall be resolved in accordance with the procedures of the Department of Labor set forth in 29 CFR parts 5, 6, and 7. Disputes within the meaning of this clause include disputes between the contractor (or any

of its subcontractors) and the contracting agency, the U.S. Department of Labor, or the employees or their representatives.

Certification of eligibility

By entering into this contract, the contractor certifies that neither it (nor he or she) nor any person or firm who has an interest in the contractor's firm is a person or firm ineligible to be awarded Government contracts by virtue of section 3(a) of the Davis-Bacon Act or 29 CFR 5.12(a)(1).

No part of this contract shall be subcontracted to any person or firm ineligible for award of a Government contract by virtue of section 3(a) of the Davis-Bacon Act or 29 CFR 5.12(a)(1).

The penalty for making false statements is prescribed in the U.S. Criminal Code, 18 U.S.C. 1001.

FEDERAL PARTICIPATION

In the announcement of any third party contract award for goods or services (including construction services), having an aggregate value of \$500,000 or more, The Authority will specify the amount of Federal assistance to be used in financing that acquisition of goods and services, and to express the amount of that Federal assistance as a percentage of the total cost of that third party contract.

NEW EMPLOYEE WORK ELIGIBILITY STATUS

The Contractor is required and hereby agrees to use a federal immigration verification system to determine the work eligibility status of new employees physically performing services within the State of Nebraska. A federal immigration verification system means the electronic verification of the work authorization program authorized by the Illegal Immigration Reform and Immigrant Responsibility Act of 1996, 8 U.S.C. 1324a, known as the E-Verify Program, or an equivalent federal program designated by the United States Department of Homeland Security or other federal agency authorized to verify the work eligibility status of a newly hired employee.

If the Contractor is an individual or sole proprietorship, the following applies:

1. The Contractor must complete the United States Citizenship Attestation Form, available on the Department of Administrative Services website at www.das.state.ne.us.
2. If the Contractor indicates on such attestation form that he or she is a qualified alien, the Contractor agrees to provide the US Citizenship and Immigration Services documentation required to verify the Contractor's lawful presence in the United States using the Systematic Alien Verification for Entitlements (SAVE) Program.
3. The Contractor understands and agrees that lawful presence in the United States is required and the Contractor may be disqualified or the contract terminated if such lawful presence cannot be verified as required by Neb. Rev. Stat. §4-108.

VETERANS PREFERENCE

Contractors working on a capital project funded using FTA assistance give a hiring preference, to the extent practicable, to veterans (as defined in section 2108 of title 5) who have the requisite skills and abilities to perform the construction work required under the contract. This subsection shall not be understood, construed or enforced in any manner that would require an employer to give a

preference to any veteran over any equally qualified applicant who is a member of any racial or ethnic minority, female, an individual with a disability, or a former employee.

SPECIAL PROVISION – TEXT MESSAGING WHILE DRIVING

In accordance with Executive Order No. 13513, Federal Leadership on Reducing Text Messaging While Driving, October 1, 2009, 23 U.S.C.A. § 402 note, and DOT Order 3902.10, Text Messaging While Driving December 30, 2009, the Grantee is encouraged to comply with the terms of the following Special Provision.

Definitions - As used in this Special Provision:

Driving: Means operating a motor vehicle on a roadway, including while temporarily stationary because of traffic, a traffic light, stop sign, or otherwise. Driving does not include being in your vehicle (with or without the motor running) in a location off the roadway where it is safe and legal to remain stationary.

Text Messaging: Means reading from or entering data into any handheld or other electronic device, including for the purpose of short message service texting, e-mailing, instant messaging, obtaining navigational information, or engaging in any other form of electronic data retrieval or electronic data communication. The term does not include the use of a cell phone or other electronic device for the limited purpose of entering a telephone number to make an outgoing call or answer an incoming call, unless the practice is prohibited by State or local law.

Safety - The Grantee is encouraged to:

Adopt and enforce workplace safety policies to decrease crashes caused by distracted drivers including policies to ban text messaging while driving:

- a) Grantee-owned or Grantee-rented vehicles or Government-owned, leased or rented vehicles;
- b) Privately-owned vehicles when on official Project related business or when performing any work for or on behalf of the Project; or
- c) Any vehicle, on or off duty, and using an employer supplied electronic device.

Conduct workplace safety initiatives in a manner commensurate with the Grantee's size, such as:

- a) Establishment of new rules and programs or re-evaluation of existing programs to prohibit text messaging while driving; and
- b) Education, awareness, and other outreach to employees about the safety risks associated with texting while driving.

Include this Special Provision in its sub-agreements with its sub-recipients and third party contracts and also encourage its sub-recipients, lessees, and third party contractors to comply with the terms of this Special Provision, and include this Special Condition in each sub-agreement, lease, and third party contract at each tier financed with Federal assistance provided by the Federal Government.

**APPENDIX D
RECEIPT OF FEDERAL CLAUSES**

Project: Exterior Repair – Sidewalk Repair

Date _____

Project No. NE-90-X104

Specification No. 14-16

I have reviewed the attached Federal Clauses for Procurement of Materials and Supplies in conjunction with Metro’s procurement of:

NE-90-X104 SPEC #: 14-16 Exterior Repair - SIDEWALK REPAIR

for which _____ has provided A QUOTE and hereby

affirm that _____ shall conform to and abide by all

aforementioned requirements as set forth and any amendments thereto.

Authorized Representative

Title

Company Name

Date

This form must be signed and submitted in bid package. All signatures must be original.

Davis-Bacon Wage Determination (Attachment 2)

General Decision Number: NE170057 04/21/2017 NE57

Superseded General Decision Number: NE20160057

State: Nebraska

Construction Type: Building
BUILDING CONSTRUCTION INCLUDING WORK ON INDUSTRIAL SITES

County: Douglas County in Nebraska.

BUILDING CONSTRUCTION PROJECTS (does not include single family homes or apartments up to and including 4 stories).

Note: Under Executive Order (EO) 13658, an hourly minimum wage of \$10.20 for calendar year 2017 applies to all contracts subject to the Davis-Bacon Act for which the contract is awarded (and any solicitation was issued) on or after January 1, 2015. If this contract is covered by the EO, the contractor must pay all workers in any classification listed on this wage determination at least \$10.20 (or the applicable wage rate listed on this wage determination, if it is higher) for all hours spent performing on the contract in calendar year 2017. The EO minimum wage rate will be adjusted annually. Additional information on contractor requirements and worker protections under the EO is available at www.dol.gov/whd/govcontracts.

Modification Number	Publication Date
0	01/06/2017
1	02/17/2017
2	02/24/2017
3	04/21/2017

BRNE0001-001 05/31/2016

	Rates	Fringes
BRICKLAYER.....	\$ 27.80	14.74

CARP0427-001 06/01/2016

	Rates	Fringes
CARPENTER (Including Acoustical Ceiling Installation).....	\$ 25.60	12.36

CARP0427-004 06/01/2016

	Rates	Fringes
PROJECT NE-90-X104	SPEC: 14-16	EXTERIOR REPAIR - SIDEWALK

CARPENTER (Drywall Hanging,
Finishing/Taping Only).....\$ 25.60 12.36

ELEC0022-001 06/01/2016

	Rates	Fringes
ELECTRICIAN.....	\$ 34.10	14.88

ELEV0028-001 01/01/2017

	Rates	Fringes
ELEVATOR MECHANIC.....	\$ 41.80	31.585+a+b

FOOTNOTE:

- a. Vacation Pay: 8% for persons with 5 or more years of service, 6% for persons with less than 5 years of service.
- b. Paid Holidays: New Year's Day, Memorial Day, Independence Day, Labor Day, Veterans' Day, Thanksgiving Day, Friday after Thanksgiving, and Christmas Day.

ENGI0571-004 10/01/2013

	Rates	Fringes
OPERATOR: Crane.....	\$ 27.08	10.69
OPERATOR: Forklift.....	\$ 21.70	10.69

IRON0021-002 06/01/2016

	Rates	Fringes
IRONWORKER, STRUCTURAL.....	\$ 28.61	14.68

* LABO1140-003 06/01/2016

	Rates	Fringes
LABORER (Mason Tender, Brick & Hod).....	\$ 20.63	9.40

PLUM0016-003 08/09/2015

	Rates	Fringes
PLUMBER (Excluding HVAC Pipe Installation).....	\$ 33.33	13.31

PLUM0464-006 05/29/2016

	Rates	Fringes
PIPEFITTER (Includes HVAC Pipe Installation and		

Excludes HVAC System
Installation).....\$ 35.04 16.44

SFNE0669-001 04/01/2016

	Rates	Fringes
SPRINKLER FITTER (Fire Sprinklers).....	\$ 33.50	18.52

SHEE0003-001 07/01/2015

	Rates	Fringes
SHEET METAL WORKER (Including HVAC Duct & System Installation).....	\$ 32.89	14.93

SUNE2011-031 10/27/2011

	Rates	Fringes
CAULKER.....	\$ 17.13	0.00
CEMENT MASON/CONCRETE FINISHER...	\$ 18.44	4.08
ELECTRICIAN (Low Voltage Wiring).....	\$ 21.54	5.99
FORM WORKER.....	\$ 19.07	3.84
GLAZIER.....	\$ 17.67	1.71
LABORER: Common or General.....	\$ 15.47	5.34
OPERATOR: Backhoe/Excavator/Trackhoe.....	\$ 22.55	5.72
OPERATOR: Bobcat/Skid Steer/Skid Loader.....	\$ 23.11	0.91
OPERATOR: Loader.....	\$ 20.76	4.64
PAINTER: Brush, Roller and Spray.....	\$ 14.26	0.00
ROOFER.....	\$ 13.57	0.77
TRUCK DRIVER, Includes Dump and Tandem Truck.....	\$ 14.77	1.41

WELDERS - Receive rate prescribed for craft performing
operation to which welding is incidental.

=====

Note: Executive Order (EO) 13706, Establishing Paid Sick Leave for Federal Contractors applies to all contracts subject to the Davis-Bacon Act for which the contract is awarded (and any solicitation was issued) on or after January 1, 2017. If this contract is covered by the EO, the contractor must provide employees with 1 hour of paid sick leave for every 30 hours they work, up to 56 hours of paid sick leave each year. Employees must be permitted to use paid sick leave for their own illness, injury or other health-related needs, including preventive care; to assist a family member (or person who is like family to the employee) who is ill, injured, or has other health-related needs, including preventive care; or for reasons resulting from, or to assist a family member (or person who is like family to the employee) who is a victim of, domestic violence, sexual assault, or stalking. Additional information on contractor requirements and worker protections under the EO is available at www.dol.gov/whd/govcontracts.

Unlisted classifications needed for work not included within the scope of the classifications listed may be added after award only as provided in the labor standards contract clauses (29CFR 5.5 (a) (1) (ii)).

The body of each wage determination lists the classification and wage rates that have been found to be prevailing for the cited type(s) of construction in the area covered by the wage determination. The classifications are listed in alphabetical order of "identifiers" that indicate whether the particular rate is a union rate (current union negotiated rate for local), a survey rate (weighted average rate) or a union average rate (weighted union average rate).

Union Rate Identifiers

A four letter classification abbreviation identifier enclosed in dotted lines beginning with characters other than "SU" or "UAVG" denotes that the union classification and rate were prevailing for that classification in the survey. Example: PLUM0198-005 07/01/2014. PLUM is an abbreviation identifier of the union which prevailed in the survey for this classification, which in this example would be Plumbers. 0198 indicates the local union number or district council number where applicable, i.e., Plumbers Local 0198. The next number, 005 in the example, is an internal number used in processing the wage determination. 07/01/2014 is the effective date of the most current negotiated rate, which in this example is July 1, 2014.

Union prevailing wage rates are updated to reflect all rate changes in the collective bargaining agreement (CBA) governing this classification and rate.

Survey Rate Identifiers

Classifications listed under the "SU" identifier indicate that no one rate prevailed for this classification in the survey and the published rate is derived by computing a weighted average rate based on all the rates reported in the survey for that classification. As this weighted average rate includes all rates reported in the survey, it may include both union and non-union rates. Example: SULA2012-007 5/13/2014. SU indicates the rates are survey rates based on a weighted average calculation of rates and are not majority rates. LA indicates the State of Louisiana. 2012 is the year of survey on which these classifications and rates are based. The next number, 007 in the example, is an internal number used in producing the wage determination. 5/13/2014 indicates the survey completion date for the classifications and rates under that identifier.

Survey wage rates are not updated and remain in effect until a new survey is conducted.

Union Average Rate Identifiers

Classification(s) listed under the UAVG identifier indicate that no single majority rate prevailed for those classifications; however, 100% of the data reported for the classifications was union data. EXAMPLE: UAVG-OH-0010 08/29/2014. UAVG indicates that the rate is a weighted union average rate. OH indicates the state. The next number, 0010 in the example, is an internal number used in producing the wage determination. 08/29/2014 indicates the survey completion date for the classifications and rates under that identifier.

A UAVG rate will be updated once a year, usually in January of each year, to reflect a weighted average of the current negotiated/CBA rate of the union locals from which the rate is based.

WAGE DETERMINATION APPEALS PROCESS

1.) Has there been an initial decision in the matter? This can be:

- * an existing published wage determination
- * a survey underlying a wage determination
- * a Wage and Hour Division letter setting forth a position on a wage determination matter
- * a conformance (additional classification and rate) ruling

On survey related matters, initial contact, including requests for summaries of surveys, should be with the Wage and Hour Regional Office for the area in which the survey was conducted because those Regional Offices have responsibility for the Davis-Bacon survey program. If the response from this initial contact is not satisfactory, then the process described in 2.)

and 3.) should be followed.

With regard to any other matter not yet ripe for the formal process described here, initial contact should be with the Branch of Construction Wage Determinations. Write to:

Branch of Construction Wage Determinations
Wage and Hour Division
U.S. Department of Labor
200 Constitution Avenue, N.W.
Washington, DC 20210

2.) If the answer to the question in 1.) is yes, then an interested party (those affected by the action) can request review and reconsideration from the Wage and Hour Administrator (See 29 CFR Part 1.8 and 29 CFR Part 7). Write to:

Wage and Hour Administrator
U.S. Department of Labor
200 Constitution Avenue, N.W.
Washington, DC 20210

The request should be accompanied by a full statement of the interested party's position and by any information (wage payment data, project description, area practice material, etc.) that the requestor considers relevant to the issue.

3.) If the decision of the Administrator is not favorable, an interested party may appeal directly to the Administrative Review Board (formerly the Wage Appeals Board). Write to:

Administrative Review Board
U.S. Department of Labor
200 Constitution Avenue, N.W.
Washington, DC 20210

4.) All decisions by the Administrative Review Board are final.

=====

END OF GENERAL DECISION

**APPENDIX E
DAVIS BACON WAGE ACKNOWLEDGEMENT**

Project: Exterior Repair – Sidewalk Repair

Date _____

Project No. NE-90-X104

Specification No. 14-16

I have reviewed the attached Davis-Bacon Preliminary Wage Determination (Attachment 1) in conjunction with Metro’s procurement of **Transit Center Water Heater Repair** for which

_____ has provided pricing and hereby affirm that

_____ shall conform to and abide by the aforementioned

requirements and as set by the Davis-Bacon Act and any amendments thereto.

Authorized Representative

Title

Company Name

Date

This form must be signed and submitted in bid package. All signatures must be original.

BIDDERS LIST DATA FORM

Metro is required pursuant to 49 CFR Part 26(c) to create and maintain a comprehensive Bidders List. This Bidders List Data Form will be used to collect bidder information used to determine the relative availability of Disadvantaged Business Enterprise (DBE) and non-DBEs, and will assist with establishing Metro's annual DBE goal. Metro's Bidders List is a compilation of bidders, proposers, quoters, subcontractors, and suppliers of materials and services who have submitted bids during the advertising period of a solicitation for services and/or goods. **Please print legibly and provide the following information:**

PART A: BUSINESS DATA

1. Business Name: _____
2. Business Address: _____

3. Contact Person: _____ Title: _____
4. Phone: () _____ Fax: () _____
5. Email Address: _____
6. Is this business a certified DBE under Nebraska's Department of Roads Unified Certification Program? ____ Yes ____ No
7. Age of Business: ____ Years ____ Months
8. Business Annual Gross Receipts:
 < \$500,000 \$500,000 to \$1,000,000 \$1,000,000 to \$2,000,000
 \$2,000,000 to \$5,000,000 >\$5,000,000

PART B: PROJECT AND WORK DESCRIPTION

9. Project Name: _____
10. Provide a brief description of the scope of work, service, and/or materials to be performed or furnished:

11. Provide the NAICS code(s) that best defines your business: _____
12. Will the business subcontract any of work, service, and/or materials? ____ Yes* ____ No
(*If Yes, then the subcontractor(s) must also complete an individual Bidders List Data Form.)

PART C: SIGNATURE

The undersigned hereby declares that the information set forth on this form is current, complete and accurate.

Authorized Signature: _____ Date: _____

Printed Name: _____ Title: _____